

Research Article

Predictive Function Optimization Control for a Class of Hydraulic Servo Vibration Systems

Xugang Feng,¹ Jiayan Zhang,¹ Jing Wang,¹ Shaokang Xiong,¹ Qiling Wu,¹ and Yetai Fei²

¹ School of Electrical and Information Engineering, Anhui University of Technology, Ma'anshan 243002, China

² School of Instrument Science and Opto-Electronics Engineering, Hefei University of Technology, Hefei 230009, China

Correspondence should be addressed to Jing Wang; jingwang08@126.com

Received 29 January 2014; Accepted 17 March 2014; Published 23 April 2014

Academic Editor: Hao Shen

Copyright © 2014 Xugang Feng et al. This is an open access article distributed under the Creative Commons Attribution License, which permits unrestricted use, distribution, and reproduction in any medium, provided the original work is properly cited.

This paper is concerned with the problem of predictive function control (PFC) for a class of hydraulic vibration servo control systems. Our aim is to design a new advanced control strategy such that the control system can track trajectory in a fast and accurate way. For this end, the mathematical model of the hydraulic vibration servo control system is firstly studied. By analyzing the nonlinear, time-varying, and model structure uncertainty features of the objects, the desired control strategy is presented based on PFC. Finally, the simulation results show that our proposed method is effective and can be used to improve the tracking speed, accuracy, and robustness.

1. Introduction

Servo system is a kind of vibration which can make the actuators change rule and the action of vibration control system according to the input signal. Hydraulic control has many advantages, such as quick response speed, high precision of vibration, and online-adjustable vibration parameters. It is not surprising that hydraulic control has been widely used in many areas, for example, the engineering construction, mechanical processing, agricultural machinery, and other industrial and agricultural production processes [1, 2]. By using crushing, piling, drilling, the work of hydraulic engineering machinery and screening, grinding, polishing, dusting, casting production technology of hydraulic vibration equipment, and so forth. Due to the complexity of working environment, hydraulic servo vibration systems are a kind of typical unknown uncertainty systems, where exist the large internal parameter changes and external load disturbance. A foundational question is, how to establish accurate mathematical model? Such a question has increased the difficulty of the control system design. In this case, the conventional linear time-invariant combination of PID control scheme is not suitable owing to the lack of the ability of quick disturbance rejection

and difficulty of coordinating the contradiction between speediness and stability and achieving the robustness of the system [3, 4].

It is well known that predictive control is suitable for the case, when the controlled object is not easy to build accurate mathematical model and also has complex industrial production process, such as petroleum, chemical industry, metallurgy, and other areas of the process industry [5]. With the development of the theory and application aspects, predictive control technology has made great development [6–9]. Predictive functional control (PFC) method [10–12] is developed on the basis of the principle of predictive control of a novel predictive control algorithm. In view of the advantages of model predictive control, it enhances the regularity of input control by introducing basis functions to improve the quickness and accuracy. The adaptive predictive functional controller has been designed based on the stability of the Laguerre model to solve the induction motor efficiency. By solving optimization problem of the maximum torque current ratio control [10] and employing feedforward compensation decoupling design idea, the considered system is decomposed into two with measurable disturbances of single into a single subsystem. The simulation experimental results

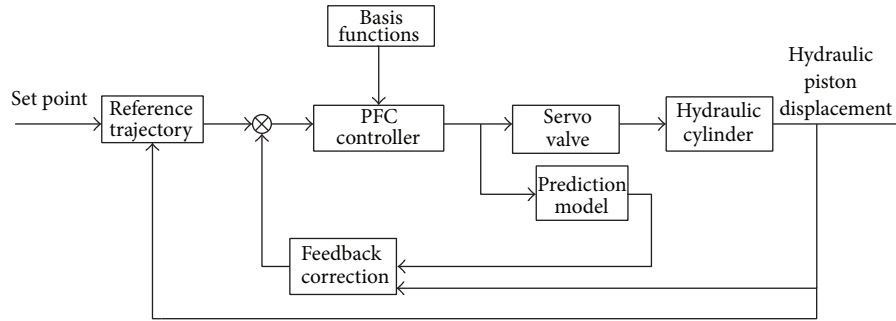

FIGURE 1: Block scheme of predictive function control (PFC).

show that compared with traditional PI current controller, the controller has high tracking precision, fast response speed, strong anti-interference ability, and the good control effect.

Time delays are frequently encountered in a variety of dynamic systems [13–16]. For the large pure time-delay system, there was a kind of inner loop PI control and outer loop using a scale factor self-tuning fuzzy incremental predictive functional control strategy, which was applied to the circuit and the main form of the object in general controlled object in [11]. A large number of simulation experiments indicated that this method was better than the other methods; even in the severe model mismatch case, it still has very strong robustness and anti-interference ability. In [12], Kautz function approximation was used to get the characterization process state space equation of object; an adaptive predictive functional controller based on Kautz was designed. In [17], the design method of the typical predictive functional controller of servo control system was given by employing the basic principle and characteristics of predictive functional control. However, to the best of our knowledge, by using the PFC method, there are few attempts that have been made to cope with the rapid servo system. Such a question has not been fully studied.

In view of the above analysis, this paper deals with the problem of hydraulic servo vibration control in engineering practice. Based on the analysis of the mathematical model of hydraulic servo vibration control system, the controlled object of nonlinear, time-varying, and uncertainty model structure, and characteristics of control system for quick tracking research, an optimal control scheme is presented in light of the predictive functional control algorithm. The effectiveness of the given PFC method is verified by MATLAB simulation which is applied to the effectiveness of the hydraulic servo system of vibration control.

2. Predictive Functional Control Algorithm Design

Predictive function control belongs to model predictive control. Compared to the traditional model predictive control, it not only has three basic characteristics (forecasting model, rolling optimization, and feedback correction) of generally predictive control but also has its own characteristics. In order to emphasize the control input, each moment added

control input is structured and seen as a linear combination of a number of preselected basis functions. By using the known processes of these basis functions, the weights of the objective function can be obtained from the optimization calculation of basis functions to get the corresponding control amount. In the hydraulic vibration servo system, operating quantity is the hydraulic servo valve opening and the output is the displacement of hydraulic piston rod. By changing the opening of the hydraulic servo valve to regulate the amount of oil hydraulic cylinder, the output displacement hydraulic piston rod is controlled. In this paper, the design of PFC control project such as Figure 1, show that PFC major compositions include: choice of basis functions, the reference trajectory prediction model, error compensation, and rolling optimization of several parts.

2.1. The Choice of Basis Functions. In the hydraulic servo predictive functional control algorithm, the control input mechanism is an important factor affecting system performance [18, 19], and consequently the role of the newly added control can be described as a linear combination of a number of basis functions:

$$u(k+i) = \sum_{n=1}^N \mu_n f_n(i), \quad (1)$$

where $i = 0, 1, \dots, P-1$ and f_n ($n = 1, \dots, N$) are basis functions, μ_n are the linear combination coefficients, $f_n(i)$ mean the value of the base functions when $t = iT$, and P represents the length of time domain prediction optimization. The selection of basis function is based on the nature of the controlled object and the requirements of desired trajectory. For example, the base functions often take a step, ramp, or exponential function. Depending on the selected basis function, the output response of the object is calculated by means of off-line.

2.2. Model Predictions. The output displacement of hydraulic servo predictive model predictive function control $y_m(k)$ is composed of model free output displacement $y_1(k)$ and model output displacement function $y_f(k)$. Model free output represents the output of the model, which is determined by the control measured amount in the past instead of

the current time and the future. The expression is given as follows:

$$y_1(k) = F(x(k)). \quad (2)$$

In this expression, F means the mathematical expression of object prediction model and $x(k)$ means the information which is known at time k . Model function output $y_f(k)$ stands for the new model response after adding controls at the present time, which is another part of the output. In the hydraulic servo predictive functional control, controlling the structure of the input is both the key to ensure the control performance and the difference between the model predictive control and other control methods. The displacement output of future model function can be expressed as

$$y_f(k+i) = \sum_{n=1}^N \mu_n g_n(i), \quad i = 1, \dots, P, \quad (3)$$

where $g_n(i)$ is the model output by $f_n(i)$; displacement model output of hydraulic servo can be calculated by the following formula:

$$y_m(k) = y_1(k) + y_f(k). \quad (4)$$

2.3. Reference Trajectories. Predictive functional control is the same as MAC, in the control process making the process output tracking reference trajectories gradually prevent dramatic changes of controlled quantity and overshoot phenomenon. For the hydraulic servo control system, reference trajectories can be as a first-order exponential form like

$$y_r(k+i) = c(k+i) - \lambda^i (c(k) - y_p(k)). \quad (5)$$

In $\lambda = e^{-T_s/T_r}$, T_s represents the sampling period, T_r means the reference trajectories time constant, and $c(k)$ is the value set.

2.4. Rolling Optimization. Optimization objective of hydraulic servo predictive model predictive function control can be expressed as

$$J = \min \left\{ \sum_{i=P_1}^{P_2} [y_r(k+h_i) - y_p(k+h_i)]^2 \right\}, \quad (6)$$

$$y_p(k+i) = y_m(k+i) + e(k+i),$$

where P_1 and P_2 are, respectively, the minimum and maximum of the optimizing time domain, $y_p(k+i)$ represents the forecast process output displacement of hydraulic servo, $e(k+i)$ is the future error of the process displacement, and $y_m(k+i)$ is the displacement output of the model at time $k+i$.

2.5. Error Prediction and Compensation. Because of the actual control process model mismatch affected by nonlinear characteristics as well as other uncertainties, the displacement of the predicted value will deviate from the actual value. In the control system, the displacement error between

hydraulic servo object and model input is sent to the predictor. Therefore it will be found as the feedforward, which is input to reference trajectory for compensation. And the future forecast displacement error is

$$e(k+i) = y(k) - y_m(k), \quad (7)$$

where $y_m(k)$ represents the model output displacement at time k .

For the next $n+i$ times prediction of displacement error in PFC algorithm, in order to improve accuracy, the polynomial fitting error is employed which is estimated based on a known time value:

$$e(n+i) = e(n) + \sum_{l=1}^{l_2} e_l(n) i^l$$

$$= y_p(n) - y_m(n) + \sum_{l=1}^{l_2} \beta_l(n) i^l, \quad (i = 1, 2, \dots, L). \quad (8)$$

Among them, $e(n+i)$ is the displacement prediction error between hydraulic servo system and model at time $n+i$; it is composed of a corrected error and error at time n . This process ($L \geq l_2 \geq 1, L \geq l_2 \geq 1, L \geq l_2$) is called self-compensation.

In PFC control algorithm, prediction horizon length P , basis function $f_n(i)$, and time coefficient of reference trajectories λ are the important parameters of controller designed. The choice of basis functions can broadly determine control accuracy, stability and robustness of the control mainly determined by the range of the prediction horizon, and the reference trajectories major impact on the dynamic response of the control system. For the impact of the system, a different design has different emphases. Therefore, it can quickly adjust the parameters according to the specific performance requirements to shorten the setting time which is a major advantage of the PFC control.

3. The Mathematical Modeling of Hydraulic Servo System

Hydraulic servo vibration system is the use of the variations in the oil pressure flow to deliver hydraulic energy and directly produce piston reciprocating cycle. Variation of pressure in the oil flow is dependent on the hydraulic vibration equipment in the process of vibration motion parameters (such as velocity, acceleration, and amplitude) or liquid parameters (such as pressure, flow, etc.) change as a feedback signal to control. Due to the advantages of high control accuracy, stiffness big, fast response speed, high speed startup, inverse kinematics, and so forth, the hydraulic control system can form of light weight, small volume, accelerating ability, quick action, and high control precision of control system, to drive the high power load. Therefore, the hydraulic servo system has been more and more widely used in the agricultural engineering machinery and equipment and production. The hydraulic servo system of the vibration control block scheme is shown in Figure 2.

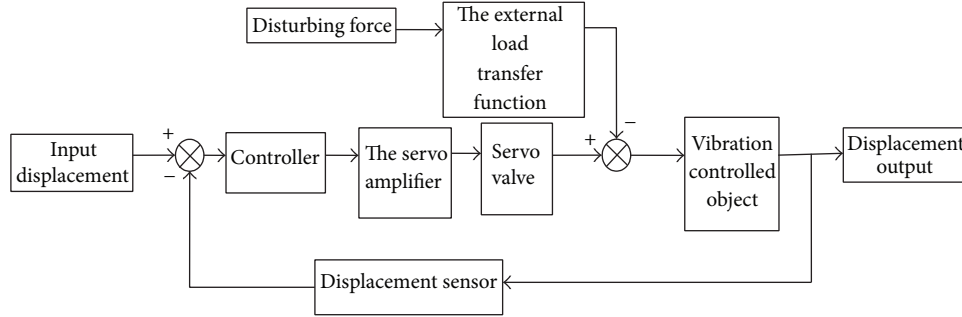

FIGURE 2: Block scheme of the hydraulic servo control system.

3.1. Basic Equation of Hydraulic Servo Valve. The hydraulic servo valve is an extremely complex closed-loop control system, which usually is as the input signal. According to physical characteristics to establish the output flow of linearized equation for [17]

$$Q_L = Q_{sv0} - K_c P_L, \quad (9)$$

where $Q_{sv0} = K_{sv} I_c$ and I_c stands for the input current signal, Q_{sv0} is the servo valve light flow, K_{sv} is the servo valve static flow of amplification coefficient, K_c stands for the pressure of the servo valve flow amplification coefficient, and P_L is for load pressure.

In view of the characteristic analysis of the hydraulic system, the servo valve has often the very high response characteristics; the dynamic can be ignored when compared with the hydraulic power components, so we can approximately regard it as a proportion of link [14]. Consider

$$\frac{Q_{sv0}}{I_c} = \frac{K_{sv}}{1 + (s/w_{sv})}. \quad (10)$$

3.2. Basic Equation of Servo Amplifier and Displacement Sensor. We can approximate the servo amplifier and displacement sensor link as proportion link; then

$$\begin{aligned} I_c &= K_p U, \\ y &= K_s x_p. \end{aligned} \quad (11)$$

By Laplace transformation,

$$Y = K_s X_p, \quad (12)$$

where y is the actual measured output by displacement sensor, K_s stands for displacement sensor amplifier gain, K_p stands for power amplifier amplification gain, and U is the output of the controller instructions.

3.3. Determining the Transfer Function. The flow gain of servo valve is as follows:

$$K_{sv} = \frac{q_n}{I_n}. \quad (13)$$

The transfer function of the servo valve is as follows:

$$G_{sv}(s) = \frac{Q_{sv}}{I_c} = \frac{K_{sv}}{(s^2/w_{sv}^2) + (2\xi_{sv}/w_{sv})s + 1}. \quad (14)$$

For transfer function of cylinder piston displacement output X_p for

$$G_V(s) = \frac{Q_L}{i} = \frac{1/A_p}{s((s^2/w_h^2) + (2\xi_h s/w_h) + 1)}. \quad (15)$$

For transfer function of external disturbance load FL input to the transfer function of cylinder piston displacement output X_p for

$$G_L(s) = \frac{X_p(s)}{F_L(s)} = \frac{-(K_{ce}/A_p^2)(1 + (V_l/4\beta_e K_{ce})s)}{s((s^2/w_h^2) + (2\xi_h s/w_h) + 1)}. \quad (16)$$

Thus, determining the system block diagram is shown in Figure 3.

Note that $K_f = A_p s$. So, the system open loop transfer function is

$$\begin{aligned} G_k(s) &= K_p G_{sv}(s) G_V(s) \\ &= \frac{1/A_p}{s((s^2/w_h^2) + (2\xi_h s/w_h) + 1)} \times K_p K_{sv} K_s. \end{aligned} \quad (17)$$

4. Simulation Result and Analysis

The hydraulic vibration, which makes use of liquid pressure, realizes vibration object sinusoidal movement up and down in the power system and servo valve for pressure control. Because of the larger vibration and impact, hydraulic vibration which is suitable for high temperature and high pressure, such as underwater environment, not only can be used for drilling, crushing, piling, and drilling, such as hydraulic pressure road engineering machinery homework tasks, but also can be used in farm, furrowing delisting, crop cultivation and harvesting, and water conservancy irrigation and agriculture engineering field [20, 21]. However, such hydraulic vibration mechanical equipment generally requires the hydraulic control system to drive the controlled according

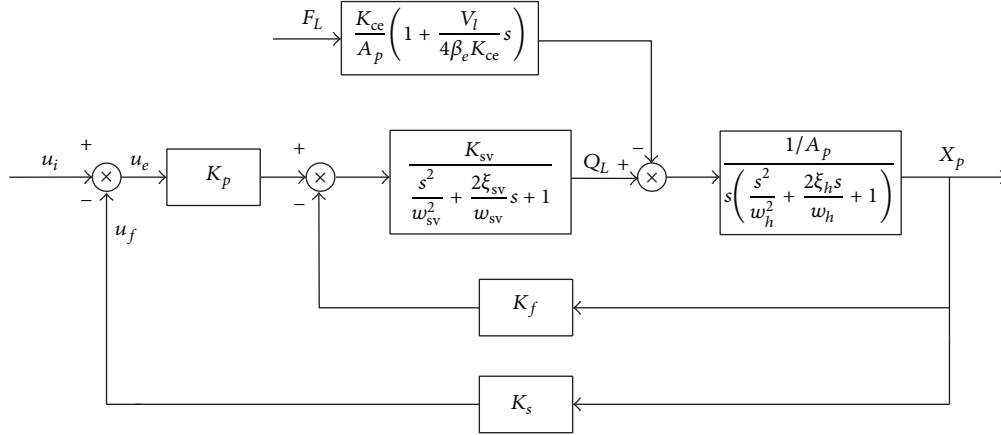

FIGURE 3: Block scheme of the hydraulic servo system.

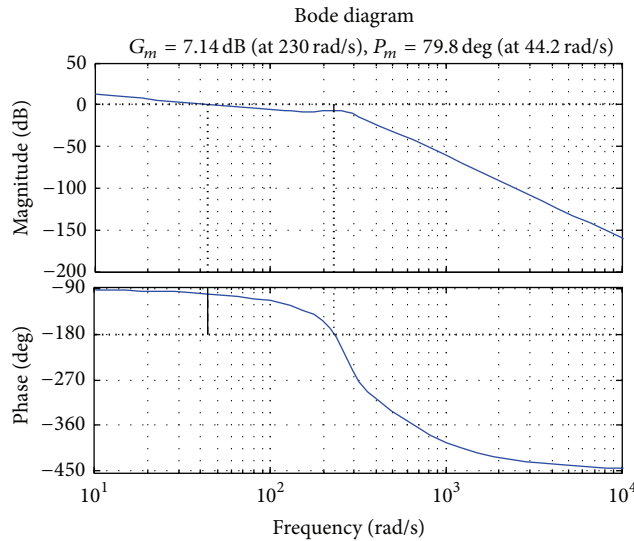

FIGURE 4: The amplitude and phase frequency characteristics of the servo system.

to the given amplitude, frequency, and the sine of the up and down reciprocating movement. This paper selects the continuous casting mould hydraulic vibration technology as an example for discussion [22]; calculation results of related parameters can be obtained as follows: $A_p = 7.91 \times 10^{-3} \text{ m}^3$, $K_p = 0.001 \text{ A/V}$, $K_{sv} = 2.5 \times 10^{-2} \text{ m}^3/(\text{s}\cdot\text{A})$, $w_h = 38 \text{ rad/s}$, $\zeta_h = 0.25$, and $K_s = 200 \text{ v/m}$. Put them into formula (17), using model conversion function `tf2ss(num,den)` of MATLAB, we can get the state space model for

$$\dot{x} = \begin{bmatrix} 2.8349 & -2.735 & 0.9002 \\ 1 & 0 & 0 \\ 0 & 1 & 0 \end{bmatrix} x + \begin{bmatrix} 1 \\ 0 \\ 0 \end{bmatrix} u, \quad (18)$$

$$y = [0.0005 \quad 0.0019 \quad 0.0005] x.$$

Through the study of the amplitude-phase frequency stability analysis of system, we obtain the system phase frequency bode diagram as shown in Figure 4.

As is shown in the figure, we can draw that the crossover frequency $w_c = 44.2 \text{ rad/s}$, phase margin $\gamma = 79.8^\circ$; when phase frequency, through -180° , $w_g = 230 \text{ rad/s}$, amplitude margin $K_g (\text{dB}) = 7.14 \text{ dB}$. We can also conclude that the system dynamic performance is poorer and the precision of tracking curve is not high when crossing frequency w_c is small.

In order to study the tracking performance of hydraulic servo vibration system, this paper selects the sine signal $R(t) = 7 * \sin(5\pi t)$ as a set point trajectory; the validity of the method of PFC can be verified via the MATLAB simulation to compare the control effect of PID and PFC. As shown in Figure 6. When using traditional PID controller to control, taking Z-N method [23], the PID gain parameters $k_p = 9.7$, $k_i = 2.5 \text{ s}$, and $k_d = 0.4 \text{ s}$. In view of the servo vibration system state space model [23], using MATLAB simulation tools, writing *M* file simulation program, PFC simulation prediction optimization time domain is 20, the reference trajectory of time constant $Tr = 2 \text{ ms}$, and sampling time is

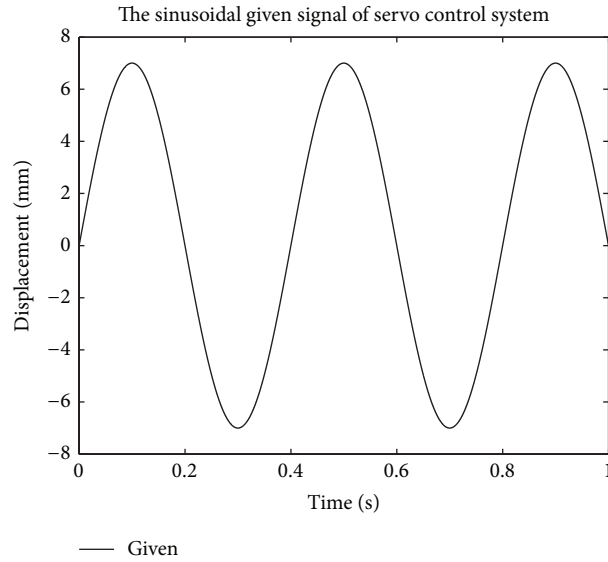

FIGURE 5: Nonsinusoidal reference signal of the servo control system.

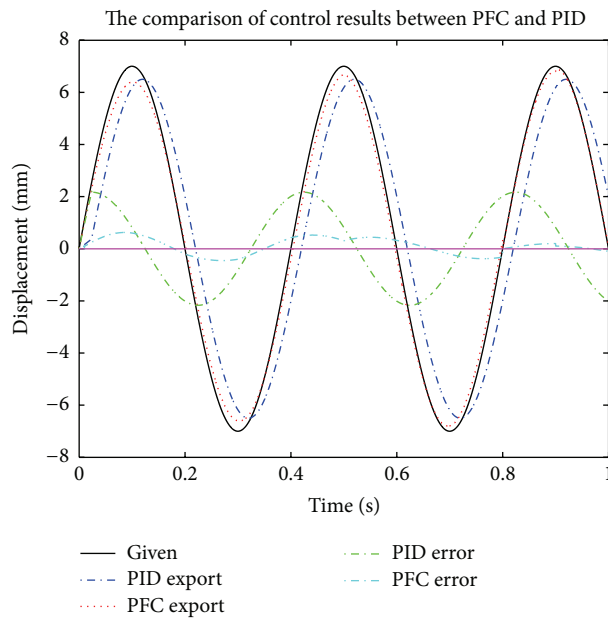

FIGURE 6: Comparison of PFC and PID control simulation results.

0.6 ms. Selecting index function $f_n(i) = i^{k-1}$ as basis function, linear combination number is 2. After the simulation under the control of predictive function, we get the results in Figures 5 and 6.

In Figure 6 there are the nonsinusoidal velocity response curves of the hydraulic servo system and error curve obtained by PFC and PID control. From Figure 6, as to traditional PID controllers, the output of the system can track the change of the input signal, but there is a certain phase lag and short of waveform completely tracking precision of the system requirements. But the displacement output settings obtained by using predictive functional control are better able to track

the trajectory and its control effect is better than conventional PID control methods.

5. Conclusion

In this paper, hydraulic servo vibration system is the specific research object, aiming at the existence and the uncertainty of its larger internal external load disturbance and parameter, based on further study of the characteristics of the hydraulic servo control system. And the predictive functional control method is applied to hydraulic servo vibration system.

The simulation result indicates that the hydraulic servo system, based on the good control quality of predictive functional control such as fast dynamic response, small overshoot, and strong stability, can effectively achieve rapid location tracking. Its control system dynamic and static quality and robustness in the case of time-varying parameters and antijamming capability are superior to the conventional PID control method. The parameter uncertainty has good robustness, with high value of engineering application.

Conflict of Interests

The authors declare that there is no conflict of interests regarding the publishing of this paper.

Acknowledgments

This work was supported by the National Natural Science Foundation of China under Grant 61304066, the Natural Science Foundation of Anhui Province under Grant 1308085QF119, and the Key Foundation of Natural Science for Colleges and Universities in Anhui Province under Grant KJ2012A049.

References

- [1] Y. Xue, N. Lu, and X. Lin, "Advances on construction vibratory mechanism," *Chinese Journal of Construction Machinery*, vol. 306, no. 2, pp. 237–242, 2008.
- [2] Y. Wang, X. Zhao, L. Xu, and X. Hou, "Progress of vibration technology application in agricultural production," *Journal of China Agricultural University*, vol. 18, no. 6, pp. 231–236, 2013.
- [3] Y. Zhang, Y. Kuang, and Y. Chen, "Design of hydraulic vibration potato harvester mining device," *Southwest China Journal of Agricultural Sciences*, vol. 26, no. 02, pp. 783–788, 2013.
- [4] J. Li, Y. Fang, and S. Shi, "Robust output-feedback control for hydraulic servo-position system of cold-strip rolling mill," *Control Theory and Applications*, vol. 29, no. 3, pp. 331–336, 2012.
- [5] J. Li, Y. Fang, and S. Shi, "Robust dynamic output-feedback control of hydraulic servo system with input saturation for rolling mill," *Control and Decision*, vol. 28, no. 2, pp. 211–217, 2013.
- [6] Y. Xi and D. Li, "Model predictive control—status and challenges," *Acta Automatica Sinica*, vol. 39, no. 3, pp. 222–236, 2013.
- [7] D. He, B. Ding, and S. Yu, "Review of fundamental properties and topics of model predictive control for nonlinear systems," *Control Theory and Applications*, vol. 30, no. 3, pp. 274–287, 2013.
- [8] G. Sun and W. Huo, "Direct-adaptive fuzzy predictive control of satellite attitude," *Acta Automatica Sinica*, vol. 36, no. 8, pp. 1151–1159, 2010.
- [9] J. Richalet, "Model predictive heuristic control: application to industrial processes," *Automatica*, vol. 15, no. 5, pp. 413–428, 2010.
- [10] J. Miao, H. Li, G. Hu, and R. Zhao, "Maximum ratio of torque to current of induction motor based on predictive functional control," *Control and Decision*, vol. 25, no. 2, pp. 218–222, 2010.
- [11] W. Dai and X. Wang, "Self-tuning fuzzy predictive functional control strategy for cascade time-delay system," *CIESC Journal*, vol. 61, no. 8, pp. 2132–2137, 2010.
- [12] M. Xu, S. Li, and C. Pan, "Predictive functional control based on kautz model with optimum compensating method," *Proceedings of the Chinese Society of Electrical Engineering*, vol. 20, no. 2, pp. 101–106, 2009.
- [13] H. Shen, J. H. Park, L. Zhang, and Z. Wu, "Robust extended dissipative control for sampled-data Markov jump systems," *International Journal of Control*, 2013.
- [14] S. He and F. Liu, "Adaptive observer-based fault estimation for stochastic Markovian jumping systems," *Abstract and Applied Analysis*, vol. 2012, Article ID 176419, 11 pages, 2012.
- [15] Z. Wu, P. Shi, H. Su, and J. Chu, "Asynchronous l_2 - l_∞ filtering for discrete-time stochastic Markov jump systems with randomly occurred sensor nonlinearities," *Automatica*, vol. 50, no. 1, pp. 180–186, 2014.
- [16] H. Shen, S. Xu, J. Lu, and J. Zhou, "Passivity-based control for uncertain stochastic jumping systems with mode-dependent round-trip time delays," *Journal of the Franklin Institute*, vol. 349, no. 5, pp. 1665–1680, 2012.
- [17] Z. Xia and G. Zhang, "Design and evaluation of predictive functional control for a servo system," *Proceedings of the Csee*, vol. 25, no. 14, pp. 130–134, 2005.
- [18] I. Škrjanc and D. Matko, "Predictive functional control based on fuzzy model for heat-exchanger pilot plant," *IEEE Transactions on Fuzzy Systems*, vol. 8, no. 6, pp. 705–712, 2000.
- [19] M. A. Brdys, M. Grochowski, T. Gminski, K. Konarczak, and M. Drewna, "Hierarchical predictive control of integrated wastewater treatment systems," *Control Engineering Practice*, vol. 16, no. 6, pp. 751–767, 2008.
- [20] Y. Xue, N. Lu, and X. Lin, "Progress of application and research on mechanical vibration technology in engineering," *Chinese Journal of Rock Mechanics and Engineering*, vol. 306, no. 2, pp. 237–242, 2008.
- [21] C. Li, R. Liang, and Z. Kan, "The application of hydraulic vibration system on tomato fruit separation device," *Journal of Agricultural Mechanization Research*, vol. 12, pp. 223–236, 2013.
- [22] L. Qiang, *Study on the System of the Thin Slab Continuous Casting Mold Driven by Hydraulic*, Yanshan University, 2010.
- [23] S. Wang, *Process Control Engineering*, Chemical industry Press, 2008.